



## **Shoring Tower Space**

Technical Instruction Manual



## Product Features

The shoring tower Space provides the necessary formwork bracing with just a few standard parts, and, at the same time, it serves as working platform for rebar or concreting works even in heights above 35m.

If particularly high vertical buildings like piers or columns have to be built, MEVA's shoring tower Space offers a safe and cost-effective alternative to conventional shoring systems. The individual tower units with a square footprint of 4.80m are pre-assembled and bolted together at ground level. The tower is built from 300cm high units which can be extended by 50cm or 100cm extension units.

### **Abbreviations, measurements, decimal numbers, figures and tables**

DIN means Deutsche Industrie-Norm (German Industrial Standard). E DIN (E = Entwurf / draft) means that the DIN is in draft status and not yet approved of. The DIBt (Deutsches Institut für Bautechnik) is the German institute that, among other construction-related tasks, drafts technical rules, prepares technical decisions and grants national and European technical approvals. Any further abbreviations are explained where they are used the first time.

Measurements: This manual uses the metric system and thus m (for metre), cm (for centimetre) and mm (for millimetre). Dimensions without a measure are in cm. Decimal numbers: Note that the comma is used in a decimal numbers, e.g. 1,5 means 1 and a half.

The page numbers in this manual start with SPACE. The figures and tables are numbered per page. Depending on its product abbreviation, a cross reference in the text refers to a page, table or figure in this or in another manual.



## Please observe

This Technical Instruction Manual contains information, instructions and hints describing how to use the MEVA equipment on the construction site in a proper, quick and economic way. Most examples shown are standard applications that will occur in practice most often. For more complicated or special applications not covered in this manual, please contact the MEVA experts for advice.

When using our products the federal, state and local codes and regulations must be observed. Many of the details shown do not illustrate the wall formwork system in the ready-to-pour condition as to the aforementioned safety regulations. Please adhere to this manual when applying the equipment described here. Deviations require engineering calculations and analysis to guarantee safety.

Please observe the assembly instructions that your local contractor or employer has created for the site on which the MEVA equipment is used. Such instructions are intended to minimise site-specific risks and must contain the following details:

- The order in which all working steps including assembly and disassembly must be carried out
- The weight of the panels and other system parts
- The type and number of ties and braces as well as the distance between them
- The location, number and dimensions of working scaffolds including working area and protection against falling down
- Pick points for panel transport by crane

Important: Generally, only well maintained material may be used. Damaged parts must be replaced. Apply only original MEVA spare parts for replacement. Attention: Never wax or oil assembly locks.

## Contents

Components .....	4
Assembly of a shoring tower Space h = 3.00 m.....	5
Material requirements per shoring tower.....	10
Assembly of security of placing.....	11
Transport.....	12
Service .....	13
Product List .....	15

## Components

The shoring tower Space provides the necessary formwork bracing with just a few standard parts.

- SP-frame (Fig. 4.1)
- SP-prop 300 (Fig. 4.2)
- SP-extension 100 (Fig. 4.3)
- SP-extension 50 (Fig. 4.4)
- SP-diagonal brace (Fig. 4.5)
- MD-beam 560 (Fig. 4.6)
- SP-guard-railing post adapter (Fig. 4.7)
- SP-connector for push-pull props (Fig. 4.8)

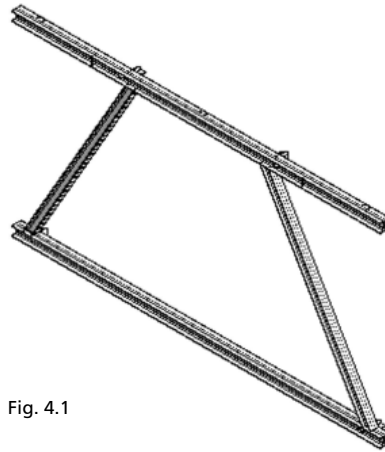

Fig. 4.1

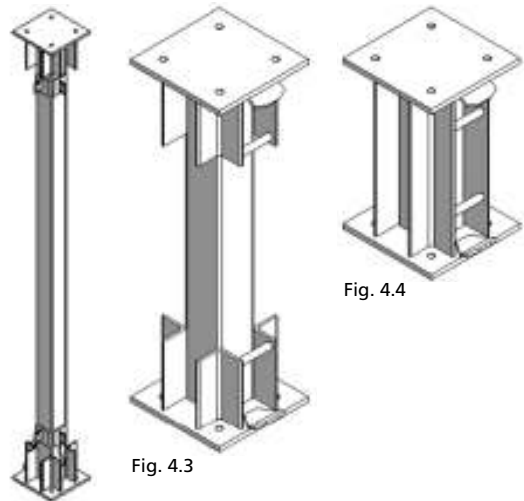

Fig. 4.2

Fig. 4.3

Fig. 4.4



Fig. 4.5

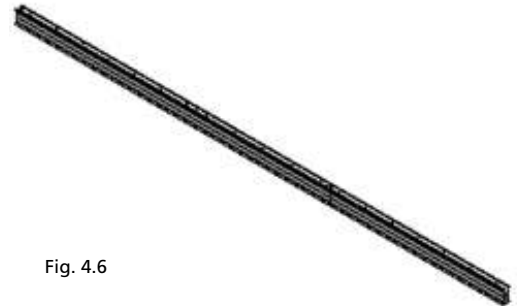

Fig. 4.6

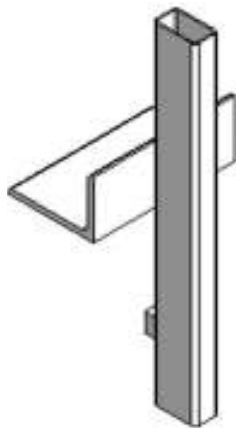

Fig. 4.7

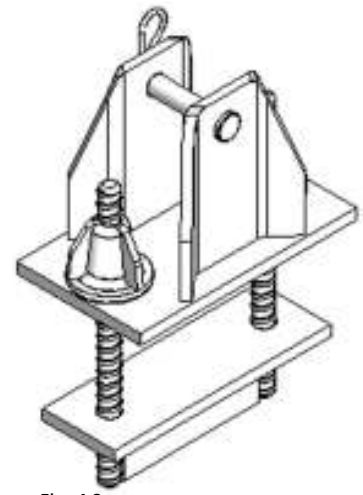

Fig. 4.8

Description	Ref. No.
SP-frame.....	29-911-40
SP-prop 300.....	29-911-45
SP-diagonal brace.....	29-911-50
SP-extension 100.....	29-911-55
SP-extension 50.....	29-911-60
MD-beam 560.....	29-911-65
SP-guard-railing post adapter.....	29-911-70
SP-connector for push-pull props.....	29-911-75

## Assembly of a shoring tower Space h = 3.00 m

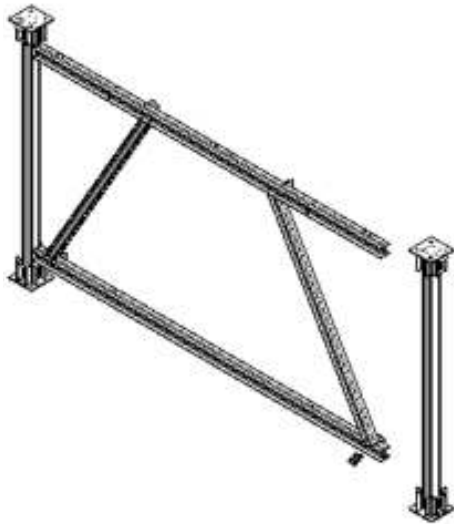

Fig. 5.1

1. Premounting of two SP-props 300 and one SP-frame (the connection between SP-frame and SP-props 300 is made by means of 4 x 2 hexagonal bolts M12x35 with washer M12 and hexagonal locking nut M12). When assembling and fixing the unit, it must additionally be secured against tilting and slipping (Fig. 5.1).

2. Premounting of one SP-prop 300 and one SP-frame (the connection between the SP-frame and the SP-prop 300 is made by means of 2 x 2 hexagonal bolts M12x35 with washer M12 and hexagonal locking nut M12). This unit must then be assembled and connected with the already standing part of the shoring tower. Screw fitting see above.

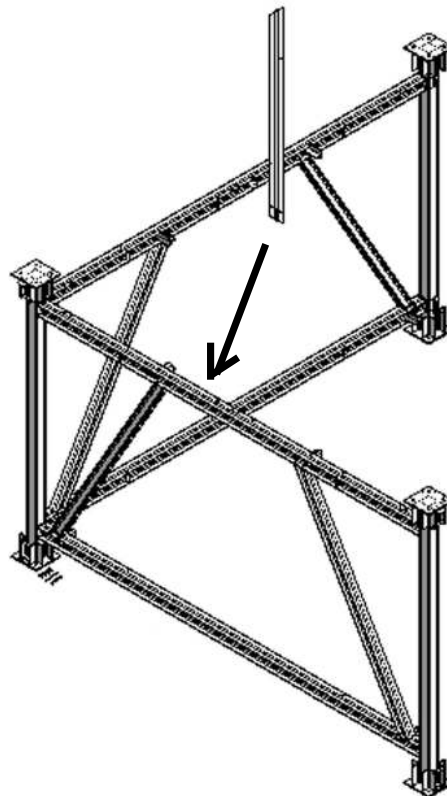

Fig. 5.2

3. Connection of the two frames with a SP-diagonal brace (made by means of 2 x 2 hexagonal bolts M12x40 with washer M12 and hexagonal locking nut M12). The support against tilting must be removed (Fig. 5.2).

Description	Ref. No.
SP-frame.....	29-911-40
SP-prop 300.....	29-911-45
SP-diagonal brace .....	29-911-50

## Assembly of a shoring tower Space h = 3.00 m

4. Premounting of one SP-prop 300 and one SP-frame. Screw fitting see step 2.

5. Connection of the two SP-frames with one SP-diagonal brace (Fig. 6.1). Screw fitting see step 3.

6. Assembly and connection of the SP-frame with the standing part of the shoring tower. Screw fitting see step 1.

7. Mounting of another two SP-diagonal braces. Screw fitting see step 3.

The measures must then be controlled and the screw fittings retightened (the measures at the bottom and at the top of the prop must be the same).

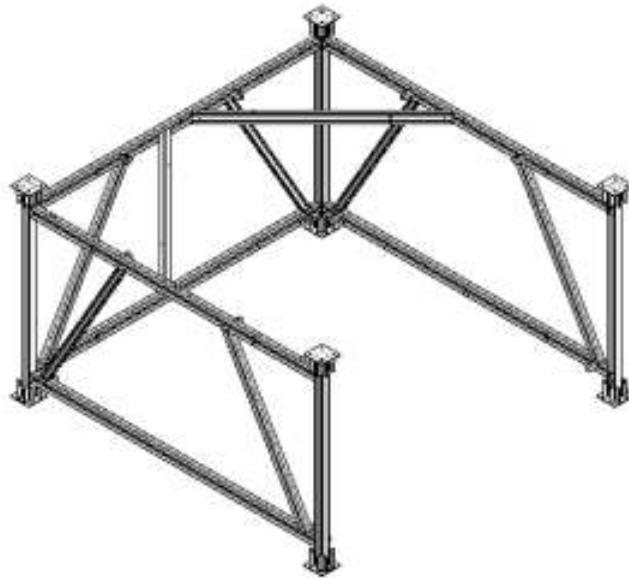

Fig. 6.1

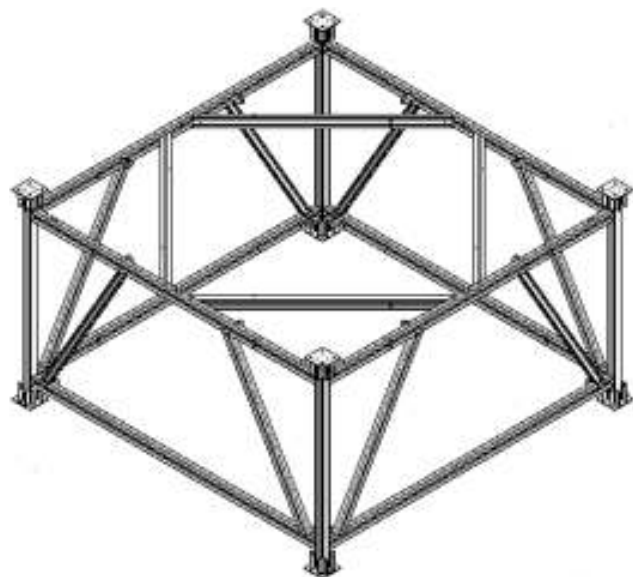

Fig. 6.2

Description	Ref. No.
SP-frame.....	29-911-40
SP-prop 300.....	29-911-45
SP-diagonal brace.....	29-911-50

## Assembly of a shoring tower Space h = 3.00 m

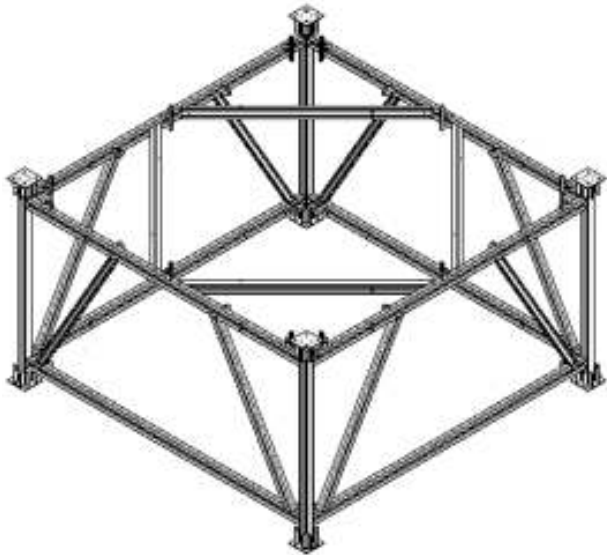

Fig. 7.1

8. Attachment of 12 SP-guard-railing post adapters to the SP-frames (Fig. 7.1). The connection between the SP-guard-railing post adapters and the SP-frame is made by means of 2 x 2 hexagonal bolts M12x35 with washer M12 and hexagonal locking nut M12.

Attachment of the guard-railing posts to the SP-guard-railing post adapters (Fig. 7.2).

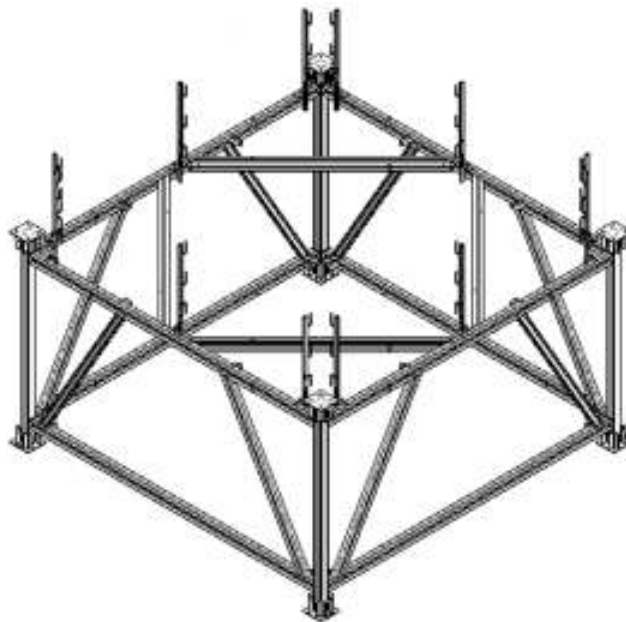

Fig. 7.2

Description	Ref. No.
SP-guard-railing post adapter .....	29-911-70
Guard-railing post 100, galv .....	29-106-75
140, galv .....	29-106-85

## Assembly of a shoring tower Space h = 3.00 m

9. Then the MD-beams 560 must be put on the SP-diagonal braces and aligned. Afterwards the MD-beams 560 must be connected and fastened to both sides of the SP-frames and SP-diagonal braces by means of MD-safety claws (Fig. 8.1 bis 8.3). In order to avoid slipping of the MD-beams 560 on the SP-frames and SP-diagonal braces.

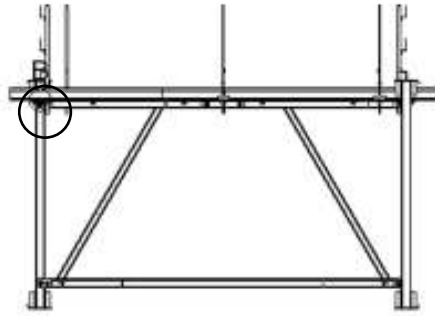

Fig. 8.1

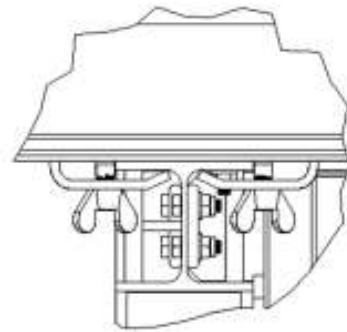

Fig. 8.2

10. If necessary, the SP connector for push-pull props can be attached to the prop in order to support the formwork at the tower and to support the tower.

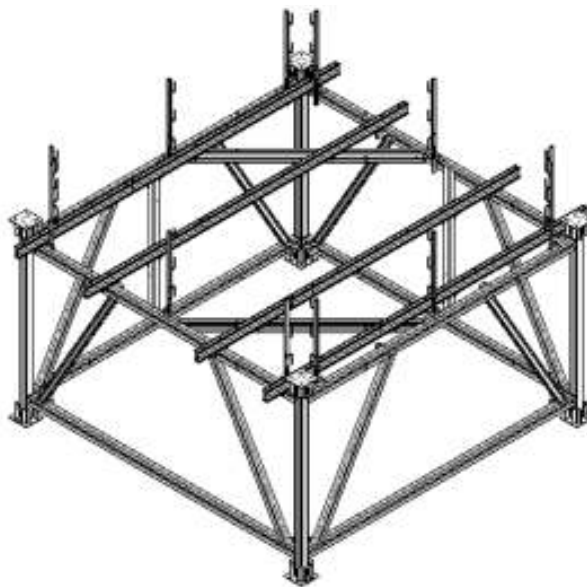

Fig. 8.3

Description	Ref. No.
MD-beam 560 .....	29-911-65
MD-safety claw .....	29-302-10
SP-connector for push-pull props.....	29-911-75



## Assembly of a shoring tower Space $h = 3.00\text{ m}$

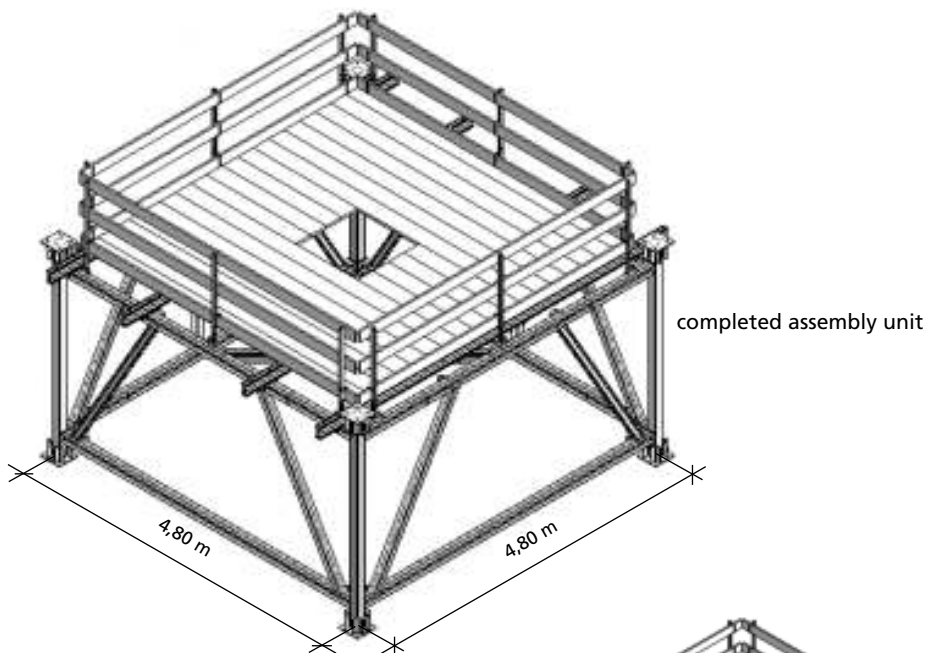

Fig. 9.1

11. Application and bolting of the planks (please keep in mind the aperture for the column with formwork and for the access ladder) and mounting of the guard-railing (Fig. 9.1).

12. It must strictly be adhered to the accident prevention regulations, when building the aperture for the access ladder.

The disassembly is to be made in reverse order.

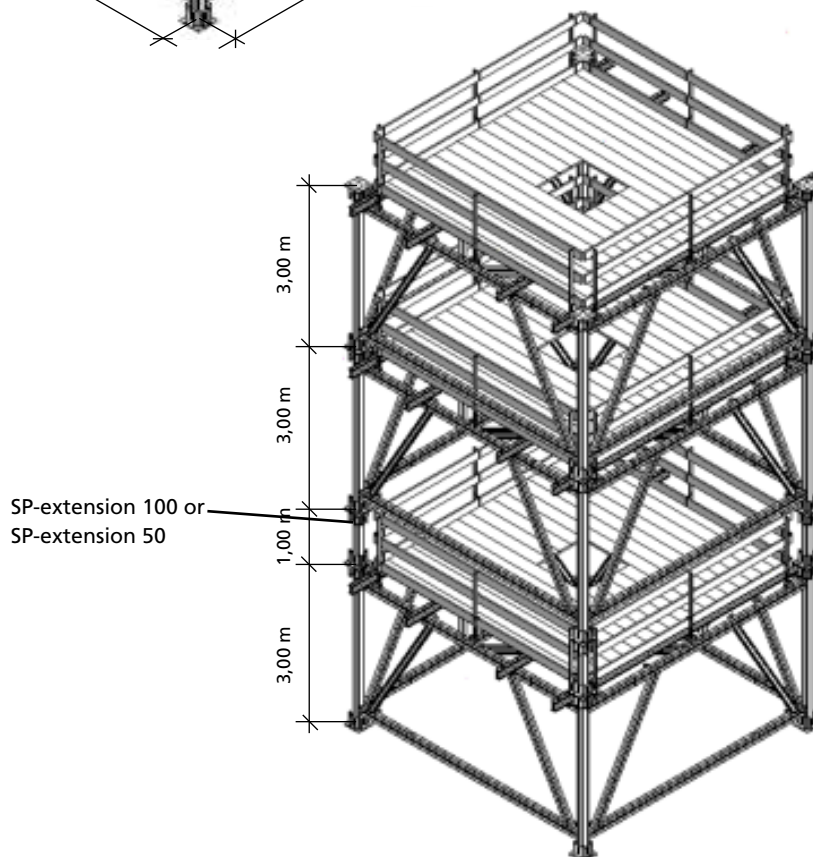

Fig. 9.2

## Material requirements per shoring tower h = 3,00 m

For each shoring tower unit h = 3.00 m, the following material is required:

Ref. No.	Description	Number
29-911-40	SP-frame	4
29-911-45	SP-prop 300	4
29-911-50	SP-diagonal brace	4
29-911-65	MD-beam 560	4
29-911-70	SP-guard-railing post adapter	12
29-106-75	Guard-railing post 100	12
29-302-10	MD-safety claw	32
Additionally the following material must be planned <b>(only for sale)</b> :		
63-120-60	hexagonal bolt M12x35	56
63-120-57	hexagonal bolt M12x40	16
63-130-10	hexagonal locking nut M12	72
62-030-41	washer M12	72
The shoring tower units can be extended at their joints by means of the SP-extension 100 or SP-extension 50.		
29-911-55	SP-extension 100	4
or		
29-911-60	SP-extension 50	4
Additionally the following material must be planned <b>(only for sale)</b> :		
63-120-46	hexagonal nut M16x60	32
63-125-50	hexagonal locking nut M16	32
62-030-48	washer M16	32
When connecting shoring tower units without SP-extensions 100 or 50, the following material must be planned <b>(only for sale)</b> :		
63-120-46	hexagonal nut M16x60	16
63-125-50	hexagonal locking nut M16	16
62-030-48	washer M16	16

Tab. 10.1

## Assembly of security of placing

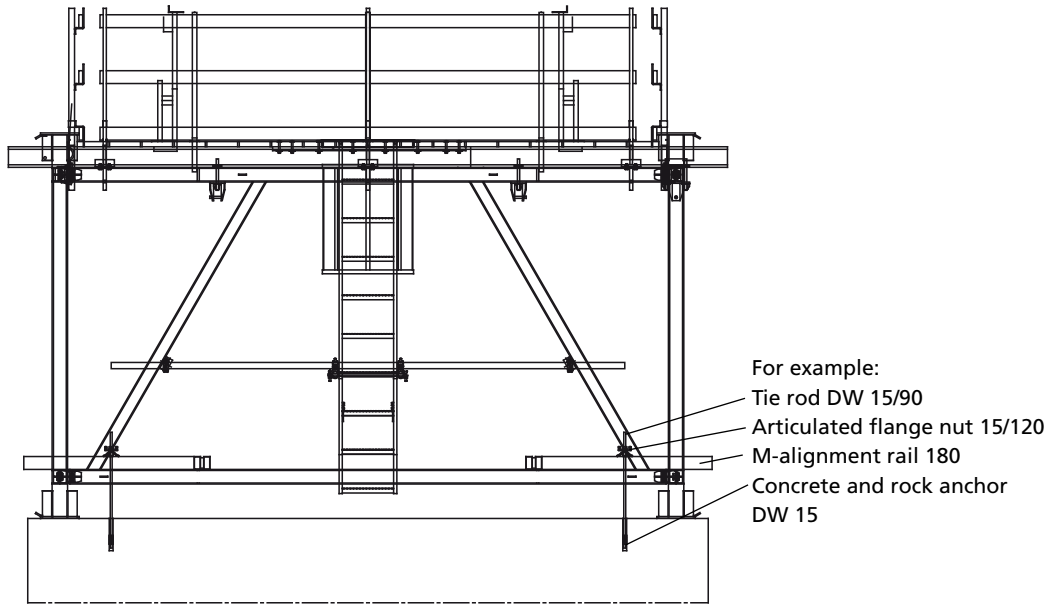

Fig. 11.1

Depending on the height of the Space tower, loads per leg, anchoring, soil pressure and size of foundation are changing. For the attachment of the securing of the installation position at the bottom of the Space tower please see the structural analysis of MEVA

Tab. 11.2

## Transport

Relocating procedure of the relocating unit

1. dismantling of the cotter pin and washer with welded hexagonal DW nut SW 30
2. plugging of the special SP crane clip 3t on the shoring tower unit  $h=3,0$  m
3. assembling of the cotter pins and the washers with the welded hexagonal DW nut SW 30
4. In case of need dismantling the scaffold joint connections at the bottom of the relocating unit; max. permissible number of shoring tower units to relocate is 3
5. relocating of the shoring tower unit / s and attaching of the shoring tower unit / s on the ground plate or the already mounted shoring tower unit / s
6. In case of need assembling of the scaffold joints connections on the bottom of the relocating unit
7. dismantling of the cotter pin and washer with welded hexagonal DW nut SW 30
8. removing of the SP crane clip 3t from the shoring tower unit  $h=3,0$  m
9. assembling of the cotter pin and washer with the welded hexagonal DW nut SW 30
10. relocating of the relocating unit (special SP-Transport spreader 12t and special SP crane clip 3t).

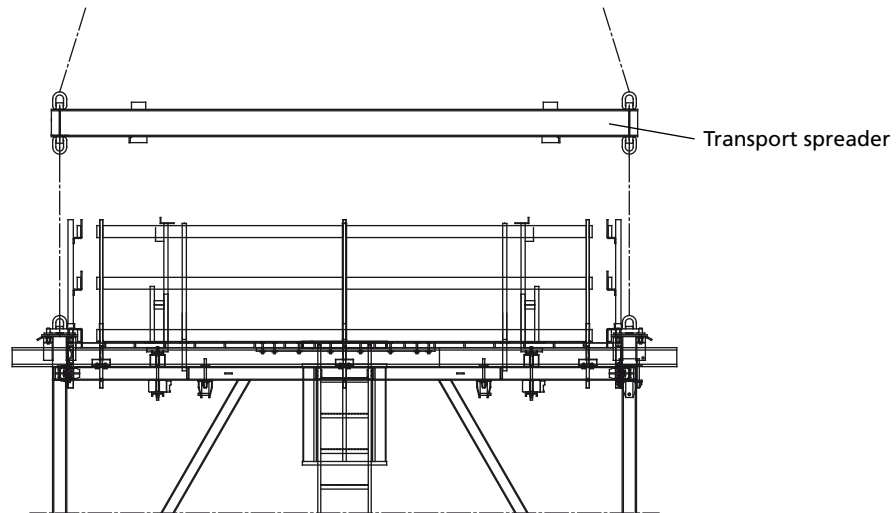

Fig. 12.1

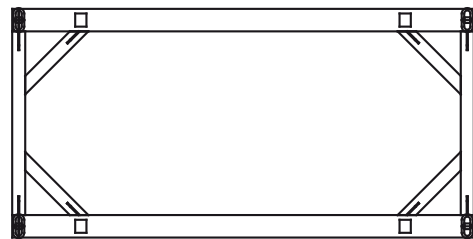

Fig. 12.2 Planview Transport spreader



### Space cleaning

The Space modules are cleaned professionally upon return.

### Cleaning and regeneration of wall formwork

Cleaning is done using industrial equipment with assembly lines.

The regeneration is carried out as follows: The frames are checked and, if necessary, repaired, painted and provided with a new facing.

As long as the formwork equipment is up-to-date, a regeneration will always be a more economical solution than purchasing new formwork.

Please note that the cleaning and regeneration service is not available in all countries in which MEVA does business.

### Rentals

With much equipment on stock, we offer our customers the option of renting supplementary material during peak times. We also give prospective customers the chance to test MEVA formwork so they can see its benefits for themselves in actual use.



### RentalPlus

Since MEVA started the flat rate for cleaning and repair of rented formwork systems in early 2000, more and more contractors experience the outstanding advantages. Ask our representatives about the details!

### Formwork drawings

Of course, all offices in our technical department have CAD facilities. You get expert, clearly represented plans and work cycle drawings.

### MBS

#### MEVA Basic Support

MBS is an addition to AutoCAD, developed by MEVA Formwork Systems in 2000. MBS is based on standard programs (AutoCAD and Excel) and can be used on any PC that has these two programs installed. It includes pull down menus for AutoCAD and applications to ease forming. It also includes the possibility to create take-offs..

### Special solutions

We can help with special parts, custom-designed for your project, as a supplement to our formwork systems.

### Static calculations

Generally, this is only necessary for applications like single-sided formwork where the anchor parts are embedded in the foundation or the base slab. If requested, we can perform static calculations for such applications at an additional charge.

### Formwork seminars

To make sure that all our products are used properly and efficiently, we offer formwork seminars. They provide our customers a good opportunity to keep themselves up-to-date and to benefit from the know-how of our engineers.

